

# GRIDSlot2

High-Performance Linear LED

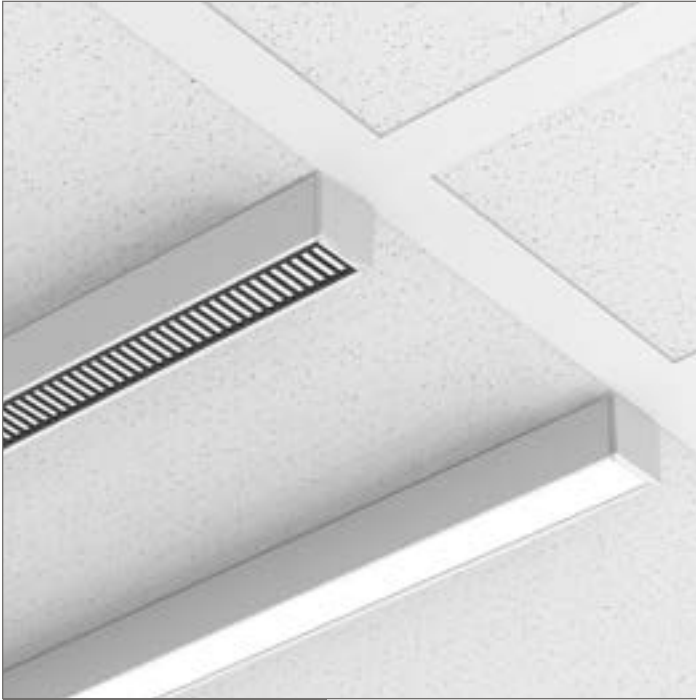

## GRIDSlot2

GRIDSlot2

### Warnings

- Risk of fire and electrical shock
- Turn off power at breaker
- Installation requires knowledge of electrical systems and should be installed by a qualified electrician. If not qualified, **DO NOT ATTEMPT INSTALLATION.**

### Care Instructions

- Wipe with a soft cloth only
- Always avoid using harsh chemicals and/or cleaners

Proceed to Page 4 for GRIDSlot2 Recessed Drywall Mount Instructions

## STEP 1 — Fixture Placement GRIDSlot2 TBar Mount

Once the grid structure has been installed, engage the GRIDSlot2 fixture into the desired location. Insert one end of the fixture at an angle and then the opposite end.

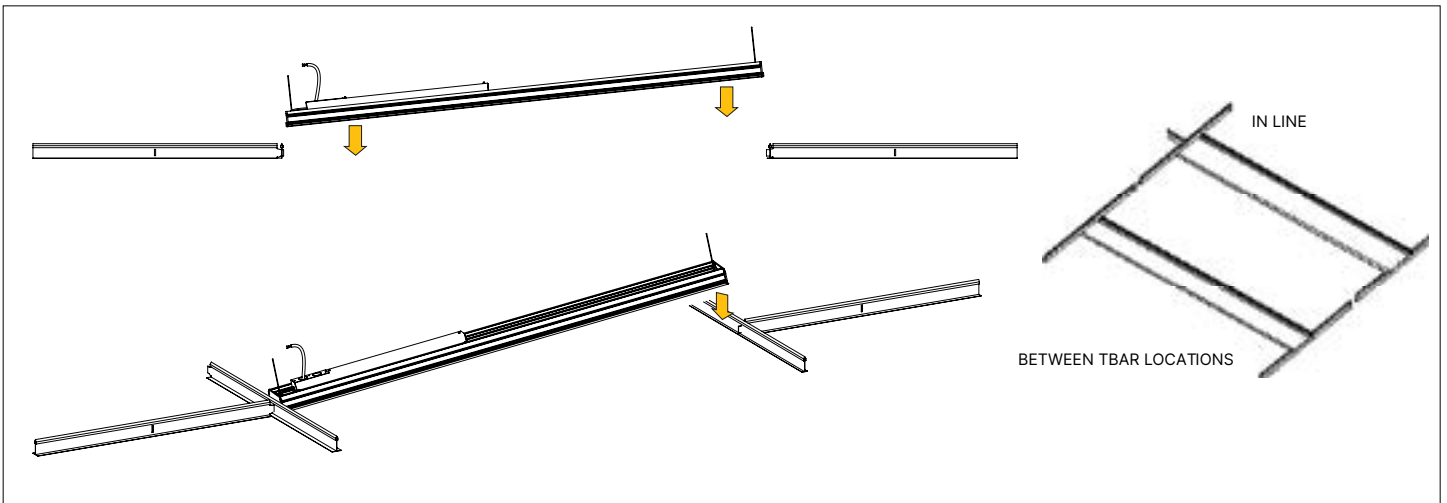

Designed & Built in  
**BOSTON**

**Declare**



**STEP 2 — Fixture Location** GRIDSlot2 TBar Mount

The GRIDSlot2 fixture can be installed in line, replacing a TBar or freely between TBar locations. When installing in line, you may be required to fold over the TBar fin, to allow clearance for the end cap.

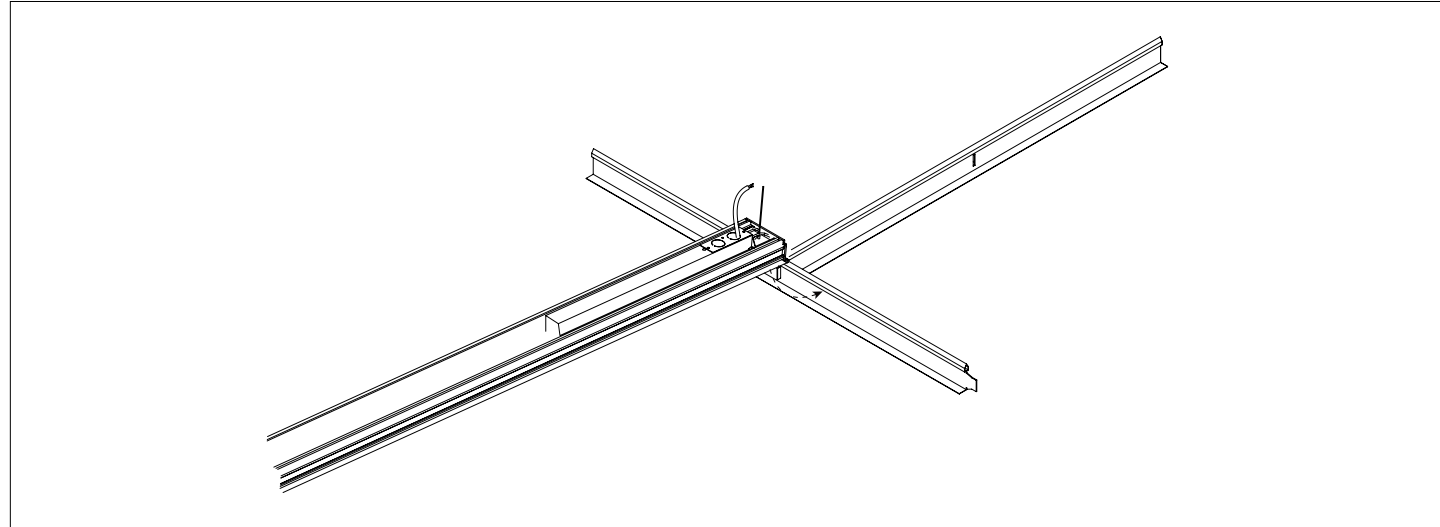

**STEP 3 — TBar Fins** GRIDSlot2 TBar Mount

If required, TBar Fins are included and can be installed anywhere along the GRIDSlot2 fixture body to receive a TBar that runs perpendicular to the fixture.

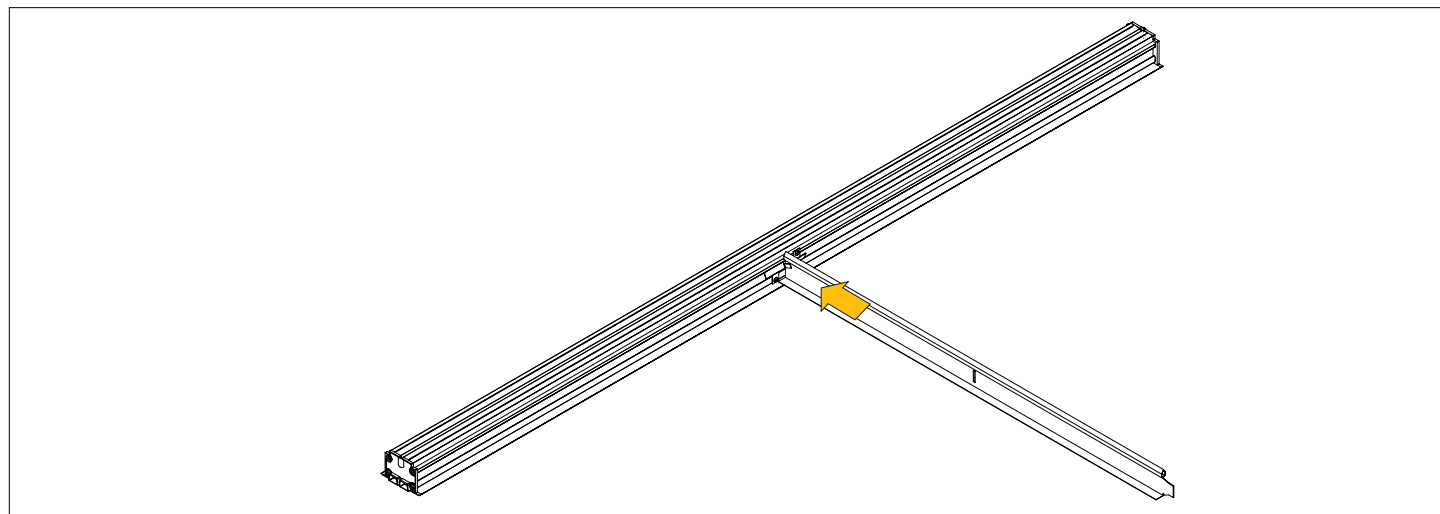

**STEP 4 — Install Driver Box** GRIDSlot2 TBar Mount

An enclosed Driver Box is provided which is either fastened to the top of the GRIDSlot2 fixture housing or loose for remote installation. Connect the fixture's Driver Box wires to the power source. Add structural supports as needed. Refer to the wiring diagram.

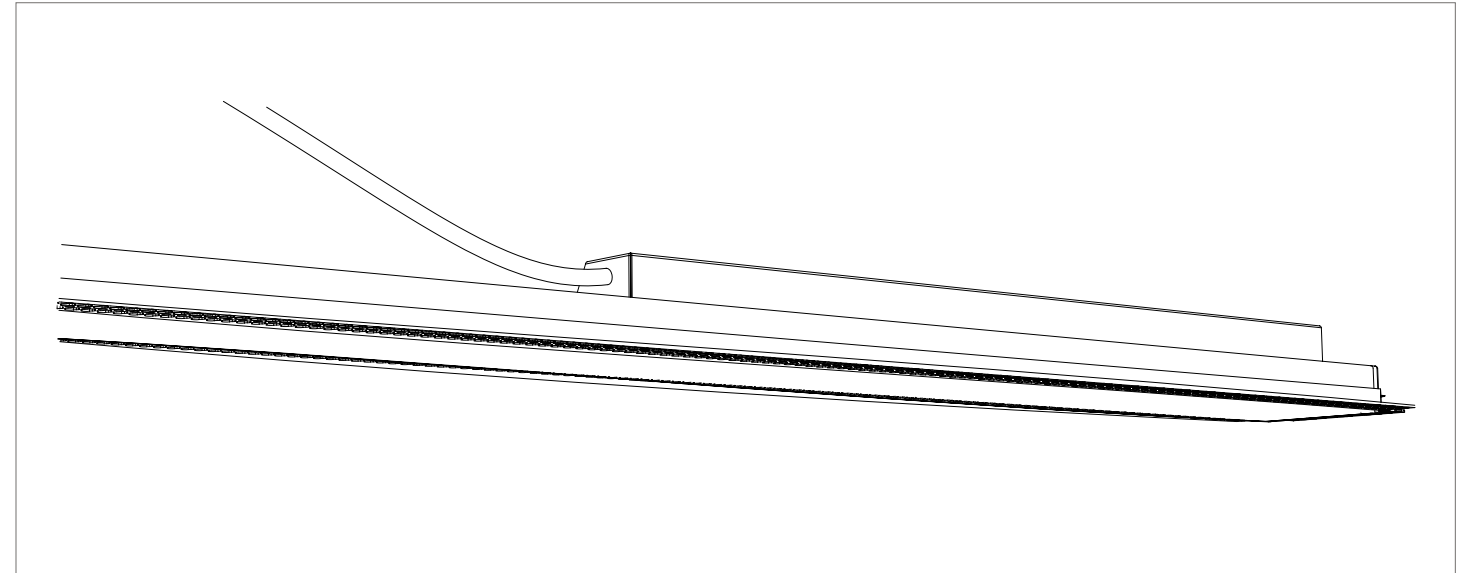

**STEP 1 — Install Driver Box** GRIDSlot2 Recessed Drywall Mount

Connect power to the GRIDSlot2 fixture. An enclosed Driver Box is provided which is fastened to the top of the fixture housing or loose for remote installation. Check to make sure you have a secure connection and that the fixture is wired correctly before proceeding to the next step. Refer to the wiring diagram.

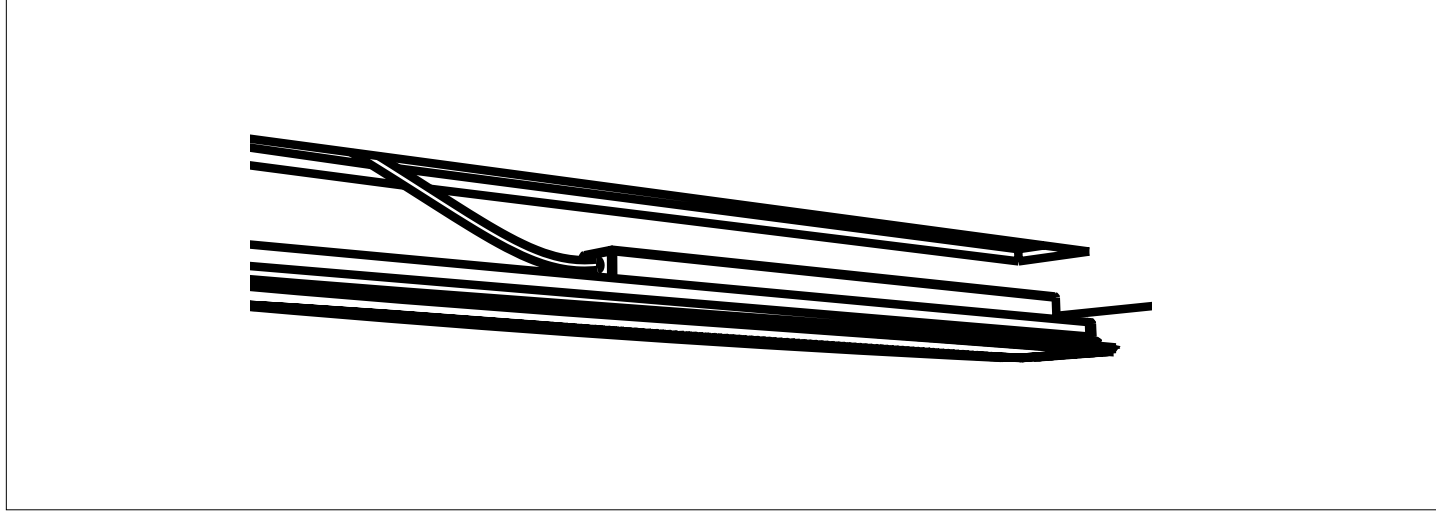

**STEP 2 — Mounting Springs** GRIDSlot2 Recessed Drywall Mount

Turn up the Mounting Springs and fit the GRIDSlot2 fixture through the drywall cutout, working your way down the fixture at each spring location.

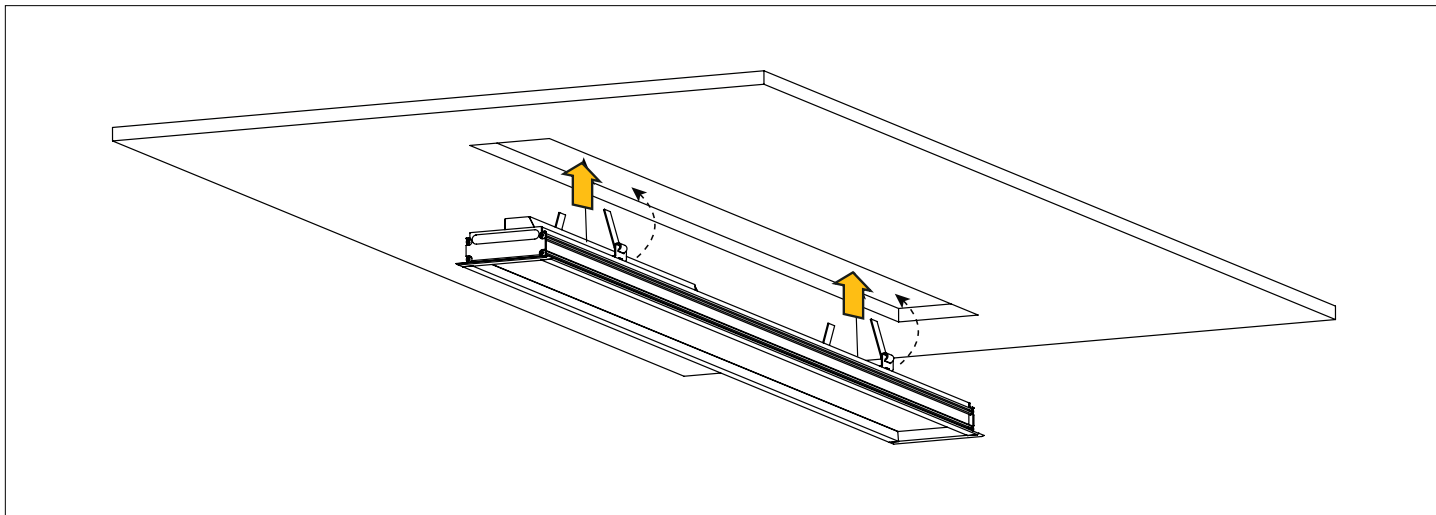

**STEP 3 — Fixture Mounting** GRIDSlot2 Recessed Drywall Mount

The springs will pull the GRIDSlot2 fixture up to the mounting surface and complete the fixture installation.

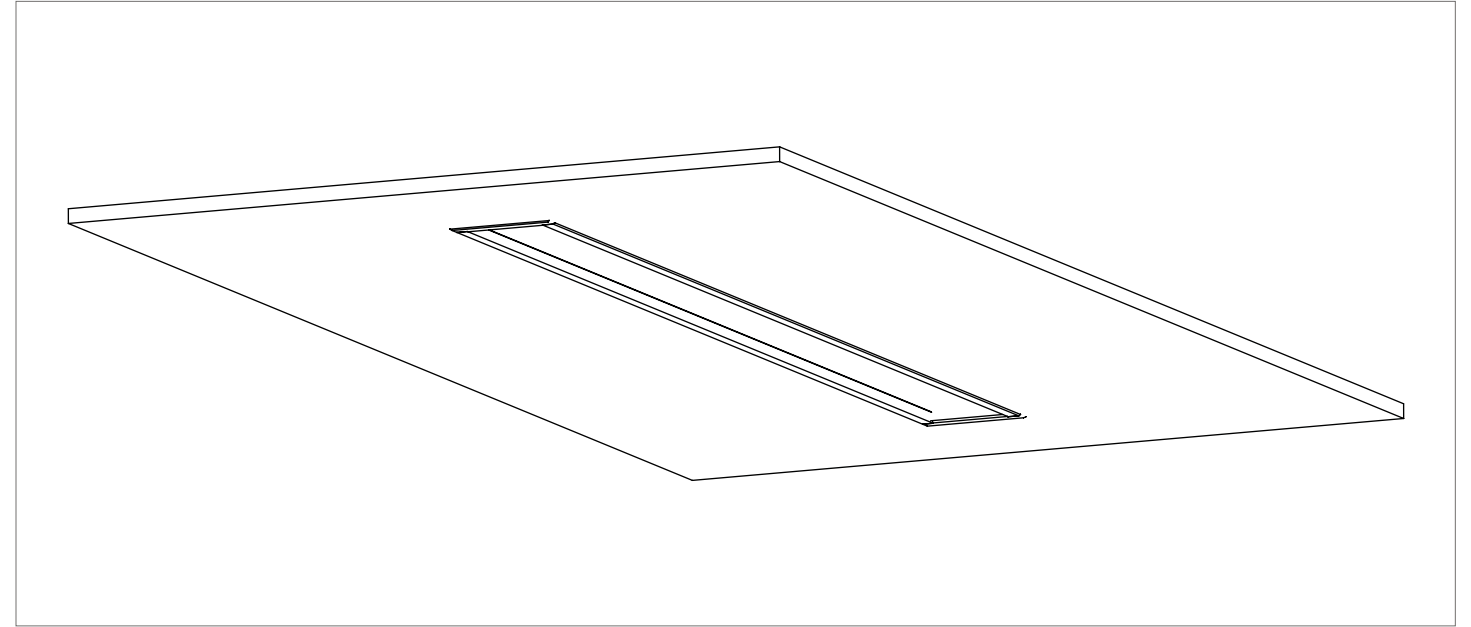

**STEP 4 — Final Installation** GRIDSlot2 Recessed Drywall Mount

The springs push against the top of the drywall surface and holds the GRIDSlot2 fixture in place.

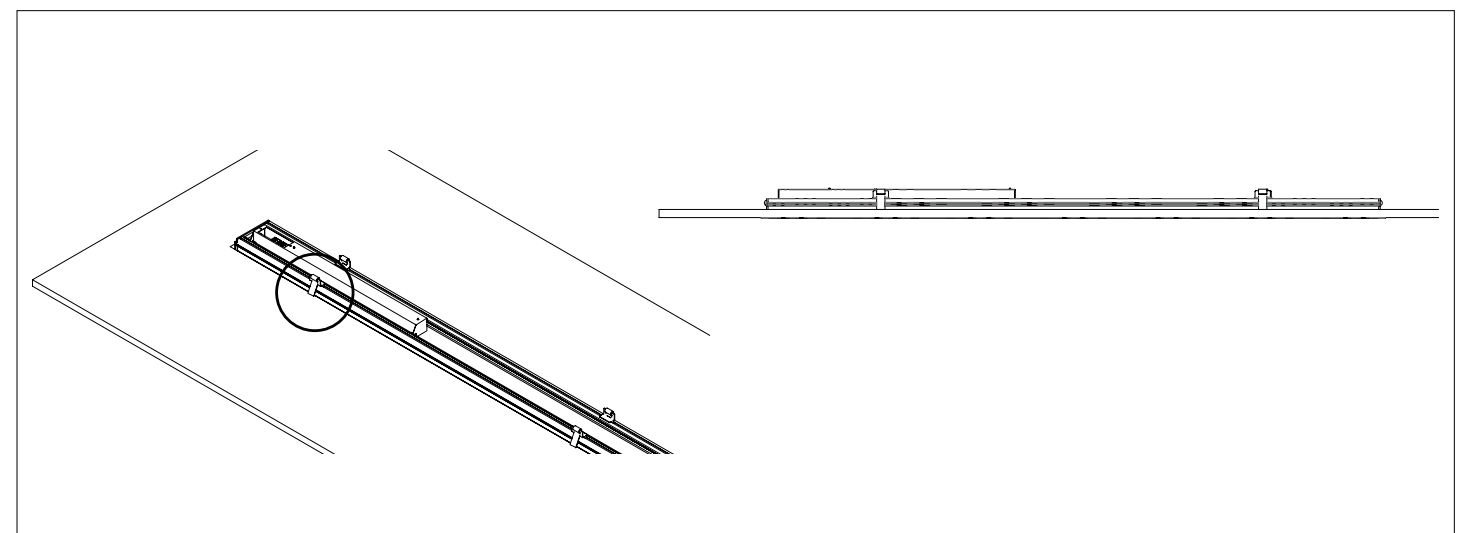

Continuous Run

**STEP 1 — Final Installation** GRIDSlot2 Continuous Run

Place the 2 GRIDSlot2 fixtures on a flat and clean surface with the open ends facing each other. The joiner bracket will be pre-installed in one of the fixtures.

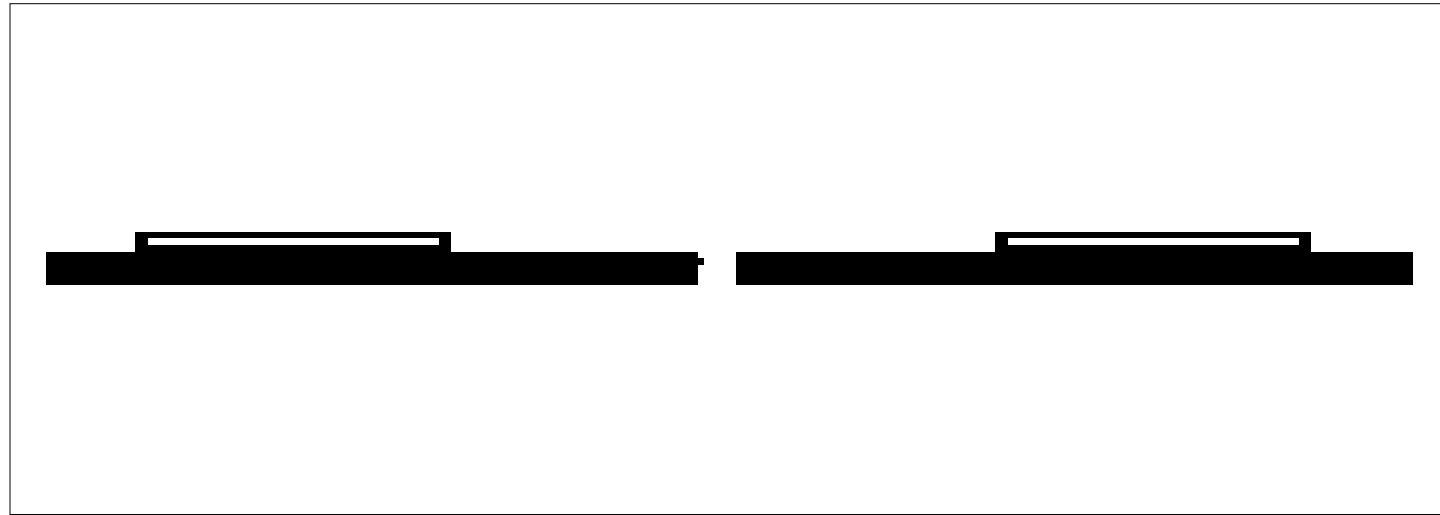

**STEP 2 — Engage the Joiner Bracket** GRIDSlot2 Continuous Run

You may be required to loosen a screw to free up the Joiner Bracket. Center the Joiner Bracket between the 2 GRIDSlot2 fixtures. Secure one side of the Joiner Bracket to the fixture housing.

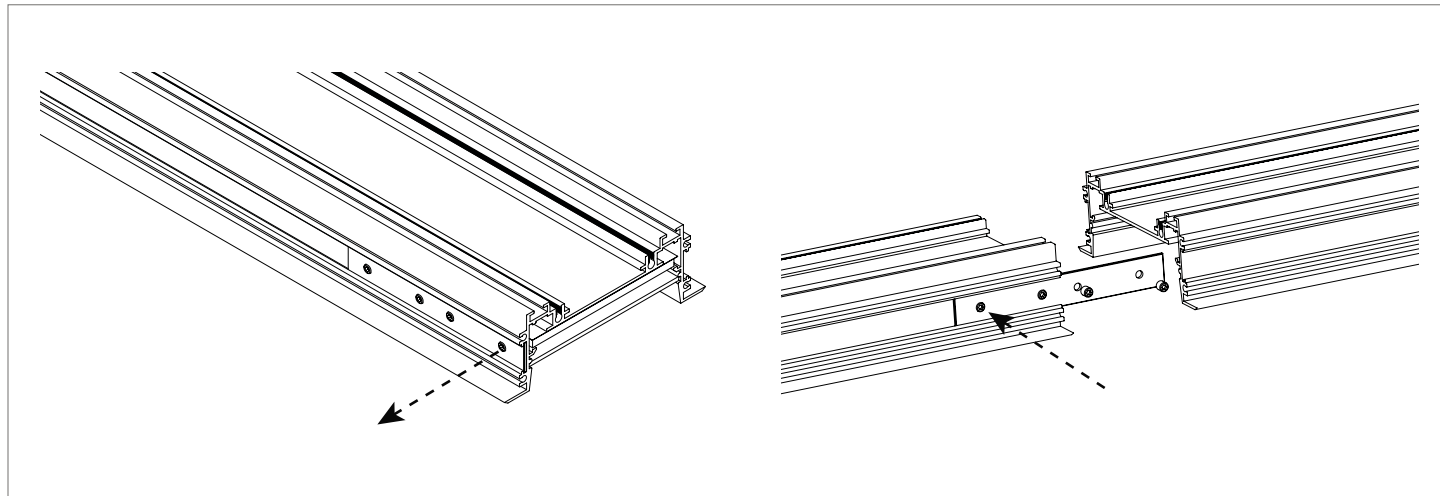

**STEP 3 — Tighten the Joiner Bracket** GRIDSlot2 Continuous Run

Pull the GRIDSlot2 fixtures together and tighten the remaining screws. Repeat steps depending on your fixture amount.

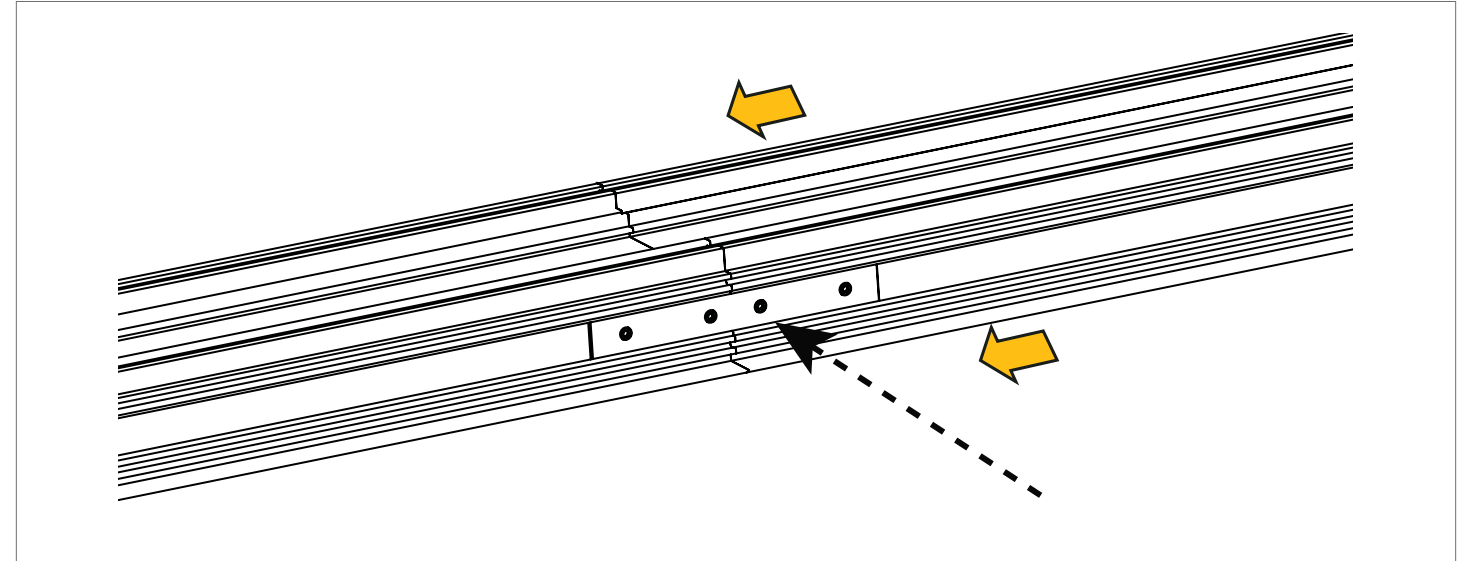

**STEP 4 — Mounting Fixture** GRIDSlot2 Continuous Run

Mount fixture to TBar or Drywall Surface with provided TBar clips or Surface Spring clips. Refer to previous pages on how to mount fixtures to TBar or Drywall Surface. Refer to previous instructions for connecting power depending on mounting type.

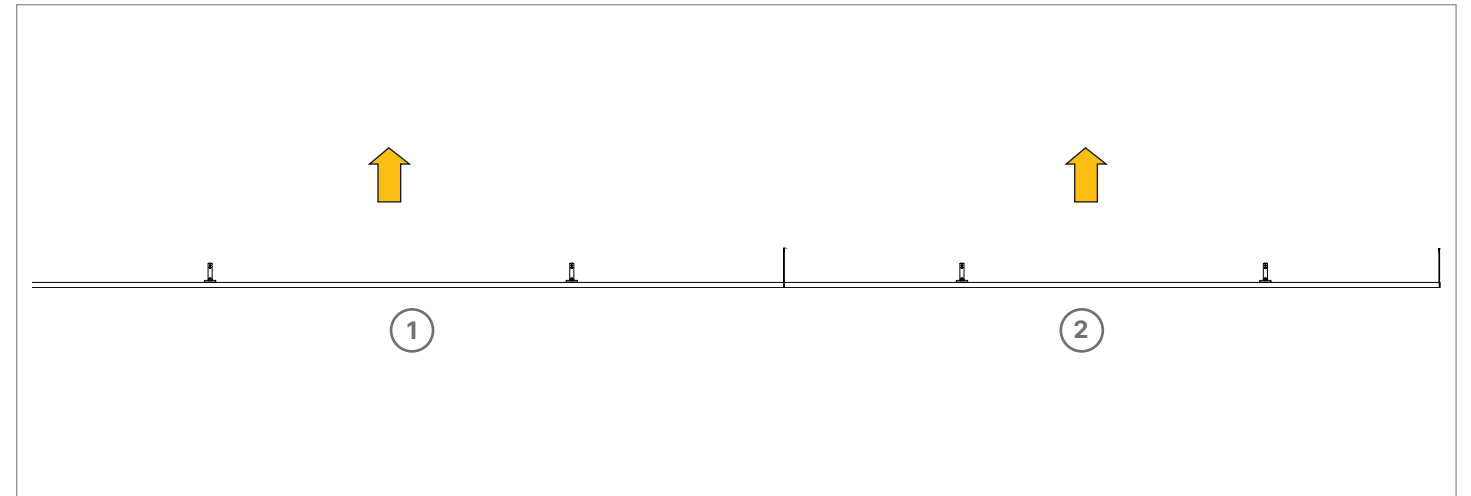

Wiring Guide

Wire the Power Feed End to the J-Box.

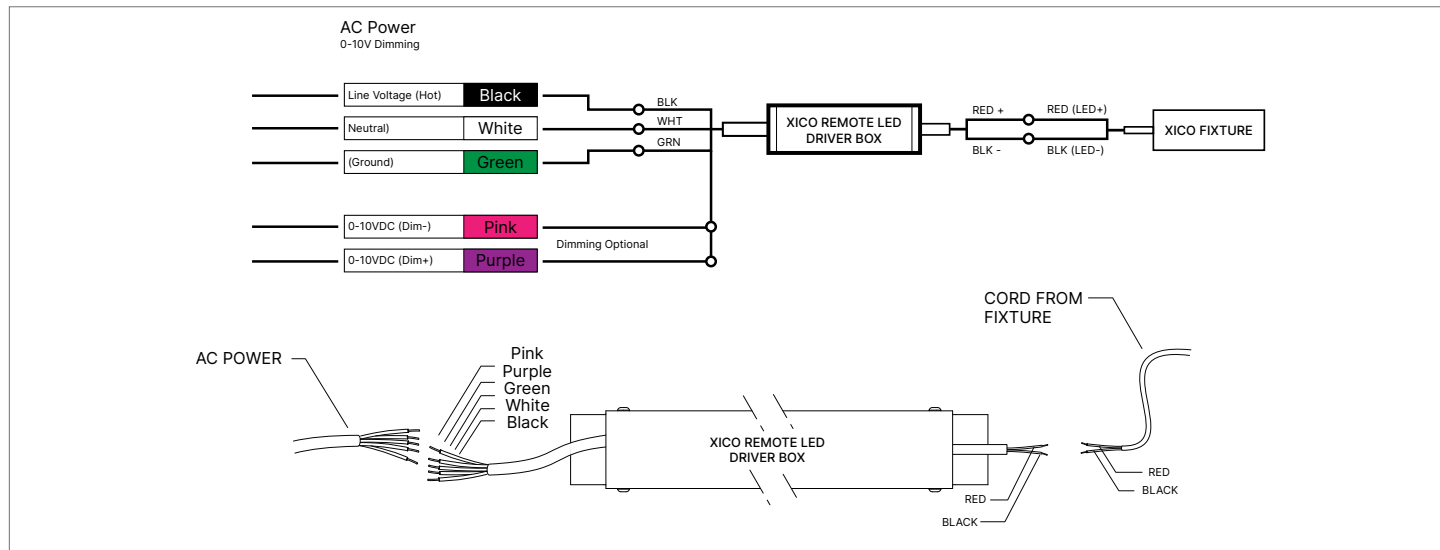

# Voltage Drop

## 24 VDC and Wire Length Chart (Driver to Fixture)

### XICO LED Fixture with Remote Drivers

When installing a XICO fixture with a remote driver and the distance is a long way from the fixture, it is important to properly specify the correct wire gauge (AWG/ or thickness of wire) for the distance of wire required. The maximum remote mounting distance is a function of the total voltage-drop across the output of the LED Driver.

### How to Use the Chart

- Step 1:** Calculate the total wattage of the LED lighting system (round up to the nearest 10 W).
- Step 2:** Find the wattage in the top row and follow the column down to maximum length (round up) of wiring between the LEDs and the power supply.
- Step 3:** Look to the left column for the wire gauge size required to prevent voltage drop over 3%.

Maximum Cable Length from Remote Driver to Fixture — 24 VDC Driver										
Wire Gauge	Total Fixture Wattage (W)									
	10 W	20 W	30 W	40 W	50 W	60 W	70 W	80 W	90 W	100 W
18 AWG	134 ft	68 ft	45 ft	33 ft	27 ft	22 ft	19 ft	17 ft	15 ft	14 ft
16 AWG	215 ft	109 ft	72 ft	54 ft	43 ft	36 ft	31 ft	27 ft	24 ft	22 ft
14 AWG	345 ft	174 ft	115 ft	86 ft	69 ft	57 ft	49 ft	43 ft	39 ft	36 ft
12 AWG	539 ft	272 ft	181 ft	135 ft	108 ft	90 ft	77 ft	68 ft	62 ft	56 ft
10 AWG	784 ft	397 ft	263 ft	197 ft	158 ft	131 ft	112 ft	98 ft	95 ft	82 ft

### Remote Driver to Fixture Example

- Calculate total load**  
An 8 ft fixture using 4 W/ft requires a total of 32 W. Round up to the nearest load of 40 W.
- Find distance from driver to Load**  
Let's assume the distance is 40 ft from the driver to the fixture. Round up to the nearest distance of 54 ft.
- Choose wire gauge**  
It's recommended to install 16 AWG wire between the driver and fixture to eliminate noticeable voltage drop.